



Electrolux
PROFESSIONAL

**Modular Cooking Range Line
thermaline 90 - 2 Zone Induction
Top, 2 Sides - MARINE**

ITEM # _____

MODEL # _____

NAME # _____

SIS # _____

AIA # _____



589842 (MCIBACEODM)

Induction Top, 2 zones, two-side operated - MARINE

Short Form Specification

Item No. _____

Unit constructed according to DIN 18860_2 with 20 mm drop nose top. Internal frame for heavy duty sturdiness in stainless steel. 2 mm top in 1.4301 (AISI 304). Flat surface construction, easily cleanable. THERMODUL connection system enables seamless worktop when units are connected and avoids soil penetrating. Smooth glass ceramic surface without any "dead" spots allows for quick and easy cleaning. Features 9 power levels with fast deployment to full heating power and very low heat dissipation to the kitchen. Overheat protection switches off the supply in case of overheating. Metal knobs with embedded hygienic silicon "soft" grip enable easier handling and cleaning. IPX5 water resistance certification. Configuration: Two-side operated top with backsplash. The base needs to be supplied by the factory. Please include the appropriate base.

Main Features

- Overheat protection: a temperature sensor switches off the supply in case of overheating.
- Pans can easily be moved from one area to another without lifting.
- The smooth glass-ceramic surface can be quickly and easily cleaned, thus providing maximum hygiene.
- All major components may be easily accessed from the front.
- THERMODUL connection system creates a seamless work top when units are connected to each other thus avoiding soil penetrating vital components and facilitating the removal of units in case of replacement or service.
- Metal knobs with embedded hygienic silicon "soft" grip for easier handling and cleaning. The special design of the controls prevent infiltration of liquids or soil into vital components.
- Large visible digital display manufactured in tempered glass to resist heat and chemicals, showing temperatures or power settings. The display also shows on/off status of the appliance and on/off status of the heating elements.
- 9 power levels.
- Fast deployment with full heating power immediately.
- Low heat dissipation to the kitchen.

Construction

- Control light for each zone.
- 2 mm top in 1.4301 (AISI 304).
- Flat surface construction with minimal hidden areas to easily clean all surfaces
- IPX5 water resistance certification.
- Internal frame for heavy duty sturdiness in 1.4301 (AISI 304).
- Unit constructed according to DIN 18860_2 with 20 mm drop nose top.
- Unit constructed according to DIN 18860_2 with 20 mm drop nose top and 70 mm recessed plinth.
- Rolling rack included

Sustainability



- This model is compliant with Swiss Energy Efficiency Ordinance (730.02).

APPROVAL: _____



Experience the Excellence
www.electroluxprofessional.com



Optional Accessories

- | | | |
|--|------------|--------------------------|
| • Scraper for cook tops | PNC 910601 | <input type="checkbox"/> |
| • Connecting rail kit, 900mm | PNC 912502 | <input type="checkbox"/> |
| • Portioning shelf, 500mm width | PNC 912523 | <input type="checkbox"/> |
| • Portioning shelf, 500mm width | PNC 912553 | <input type="checkbox"/> |
| • Folding shelf, 300x900mm | PNC 912581 | <input type="checkbox"/> |
| • Folding shelf, 400x900mm | PNC 912582 | <input type="checkbox"/> |
| • Fixed side shelf, 200x900mm | PNC 912589 | <input type="checkbox"/> |
| • Fixed side shelf, 300x900mm | PNC 912590 | <input type="checkbox"/> |
| • Fixed side shelf, 400x900mm | PNC 912591 | <input type="checkbox"/> |
| • Connecting rail kit: modular 90 (on the left) to ProThermetic tilting (on the right), ProThermetic stationary (on the left) to ProThermetic tilting (on the right) | PNC 912975 | <input type="checkbox"/> |
| • Connecting rail kit: modular 80 (on the right) to ProThermetic tilting (on the left), ProThermetic stationary (on the right) to ProThermetic tilting (on the left) | PNC 912976 | <input type="checkbox"/> |
| • Endrail kit, flush-fitting, left | PNC 913111 | <input type="checkbox"/> |
| • Endrail kit, flush-fitting, right | PNC 913112 | <input type="checkbox"/> |
| • Endrail kit (12.5mm) for thermaline 90 units, left | PNC 913202 | <input type="checkbox"/> |
| • Endrail kit (12.5mm) for thermaline 90 units, right | PNC 913203 | <input type="checkbox"/> |
| • Insert profile d=900 | PNC 913232 | <input type="checkbox"/> |
| • Filter W=500mm | PNC 913664 | <input type="checkbox"/> |



Front

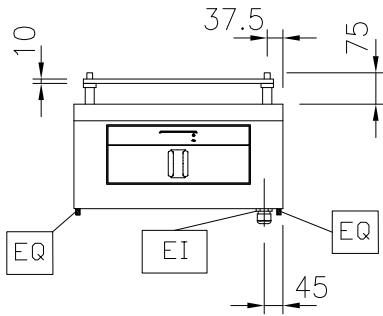

Side

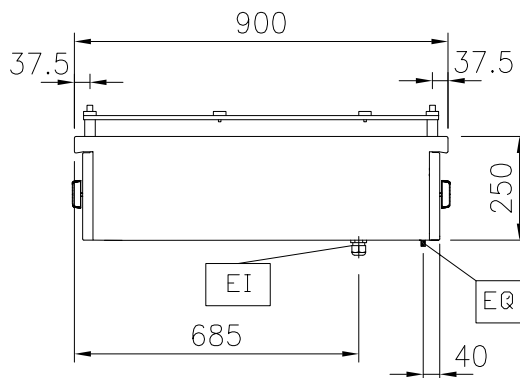

EI = Electrical inlet (power)
 EQ = Equipotential screw

Top

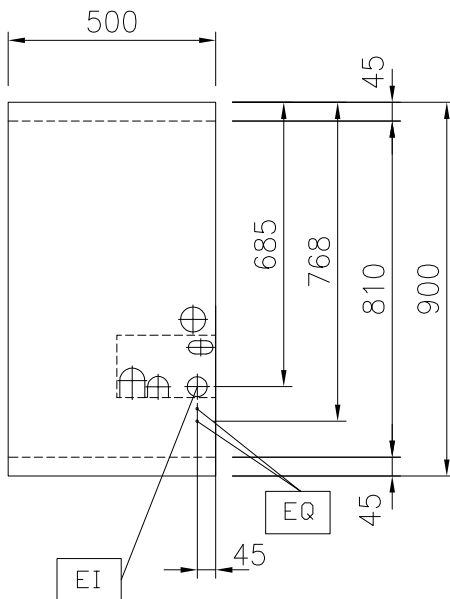

Electric

Supply voltage:

589842 (MCIBACEODM) 440 V/3 ph/50/60 Hz

Total Watts:

10 kW

Key Information:

Configuration: Both-Sides Operated;Top

Front Plates Power: 5 - 0 kW

Back Plates Power: 5 - kW

Front Plates dimensions: 340x370

Back Plates dimensions: 340x370

Induction Top Dimensions (width): 500 mm

Induction Top Dimensions (depth): 900 mm

External dimensions, Width: 500 mm

External dimensions, Depth: 900 mm

External dimensions, Height: 250 mm

Net weight: 25 kg

Sustainability

Current consumption: 13.7 Amps